

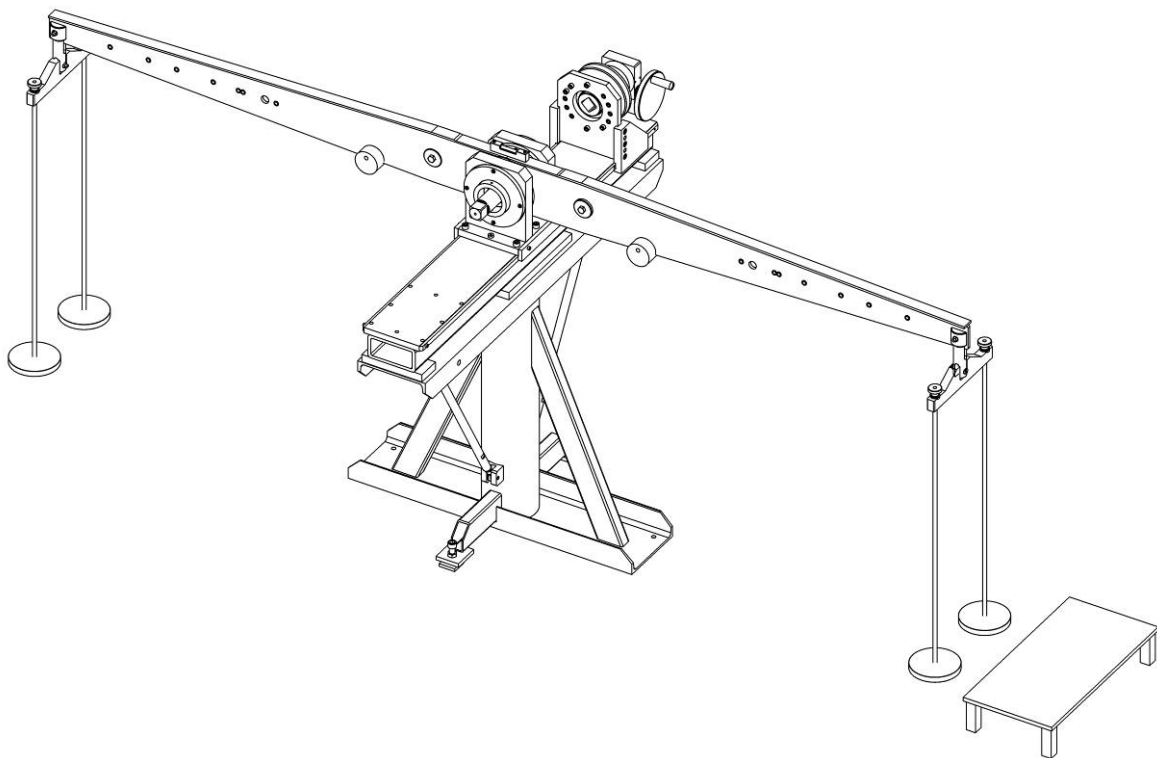

SUPPORTED TORQUE CALIBRATION BEAM

OPERATOR'S MANUAL (PART NO. 34320) Issue 3
(ENGLISH)



NORBAR TORQUE TOOLS LTD, Beaumont Road, Banbury, Oxfordshire, OX16 1XJ, UNITED KINGDOM
Tel: + 44 (0) 1295 270333

www.norbar.com

enquiry@norbar.com

CONTENTS

	<u>PAGE</u>
Part Numbers Covered by This Manual	2
Safety	2
Introduction	2
Features and Functions	3
External Effects	3
Set up Instructions	5
1. Fixing Pedestal	5
2. Beam & Bearing Support	6
3. Levelling Gearbox	7
4. Hangers	7
Operating Instructions	8
1. Locating Transducer	8
2. Locating Hangers	9
3. Exercising	10
4. Calibration	10
Maintenance	11
Specification	12
Trouble shooting	12
Glossary of terms	12

PART NUMBERS COVERED BY THIS HANDBOOK

PART NUMBER	TORQUE	
	N·m	lbf·ft
21842	500 - 5000	500 – 5000

SAFETY

It is recommended that safety shoes are worn. Use safe manual handling techniques when lifting.

INTRODUCTION

This calibration beam is designed for the static calibration of torque transducers. Torque is generated by the application of a known force (weights) at a known radius from the centre of rotation of the torque transducer. Reaction is taken via a levelling gearbox so the beam can be kept horizontal.

PARTS INCLUDED:-

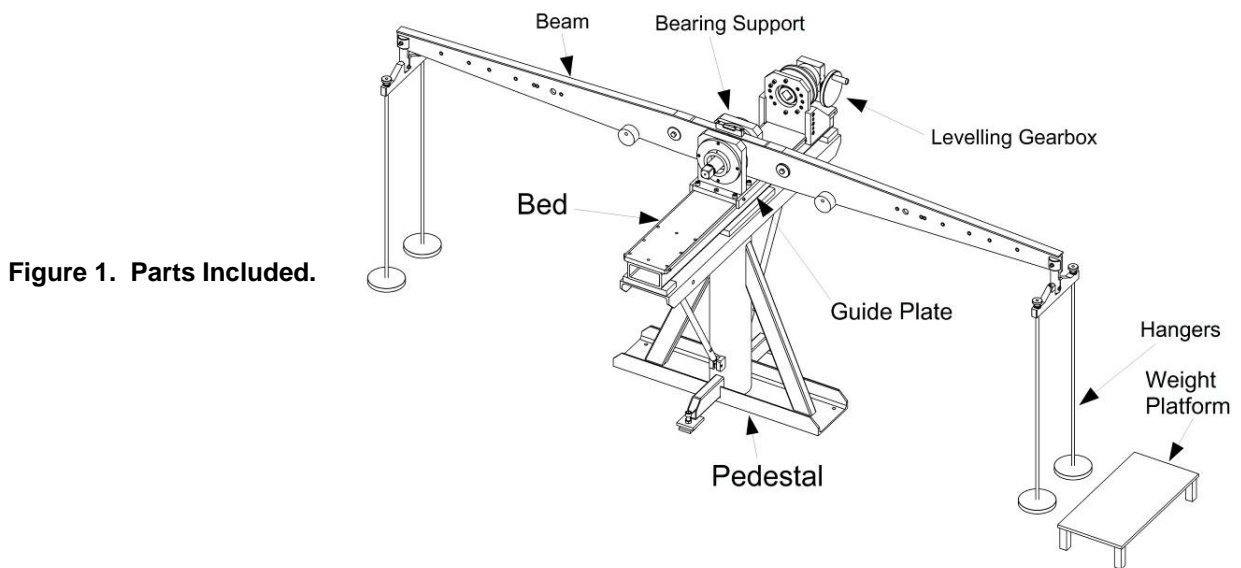

DESCRIPTION	QUANTITY
Beam with bearing support	1
Pedestal with bed	1
Levelling gearbox	1
Jacking plate	2
Torque wrench	1
M8 Bolt (25354.90) (Bearing support to pedestal)	2
M6 Bolt (25353.25) (Guide plate to bed)	4

DESCRIPTION	QUANTITY
Guide plate	2
Hangers	2
Weight platform	1
Raw bolts	4
Calibration certificate	1
M12 Bolt (25356.35) (Bearing support to pedestal)	6
Handbook	1

ACCESSORIES:-

PART NUMBER	DESCRIPTION
21469.NAM	Set of 20 x 50 lbf weights to give 5000 N·m / 5000 lbf·ft

FEATURES AND FUNCTIONS

TRANSDUCER COMPATIBILITY

The calibration beam is ideally suited to Norbar torque transducers, but may be used on other manufacturer's equipment.

BEAM ALIGNMENT

A self-locking gearbox provides an easy method of keeping the beam horizontal once loaded.

TRACEABILITY

The beams and weights are guaranteed within a tolerance of accuracy and traceable certification is provided.

TORQUE ACCURACY

The beam and its associate stand have been robustly constructed to ensure only torque is applied to the transducer under test. Any torque losses (through bending or bearing loss) seen by the transducer have been minimised. Weight accuracy is required to be equal to or better than 0.01% which approximates to class M1.

CLOCKWISE / COUNTER CLOCKWISE OPERATION

The symmetrical beams allow for both clockwise and counter clockwise calibration.

EXTERNAL EFFECTS

TEMPERATURE COMPENSATION:- _____

The calibration beam should be used in a temperature controlled environment of 20°C +/- 2°C. If the beam must be used outside these limits, the temperature must be stable (within 1°C change per hour) and the effective length of the beam calculated according to the details below.

The Coefficient of linear expansion for steel is $12 \times 10^{-6} / ^\circ\text{C}$ or (0.000012 per °C)

The formula for calculating the change in effective beam length is:-

Change in length =

Initial beam radius x Coefficient of linear expansion x Change in temperature in °C (from 20°C Nominal)

Example: 1 metre radius beam used at 24 °C.

Change in length = Initial beam radius x $(12 \times 10^{-6}) \times 4$

Change in length = $1 \times (12 \times 10^{-6}) \times 4$

Change in length = 4.8×10^{-5}

Change in length = 0.000048 metre

New effective beam radius = Initial beam radius + Change in length

New effective beam radius = 1.000048 metre

Example: 1 metre radius beam used at 16 °C.

Change in length = Initial beam radius x $(12 \times 10^{-6}) \times -4$

Change in length = $1 \times (12 \times 10^{-6}) \times -4$

Change in length = -4.8×10^{-5}

Change in length = -0.000048 metre

New effective beam radius = Initial beam radius + Change in length

New effective beam radius = 0.999952 metre

GRAVITATIONAL EFFECTS:- _____

It is very important that the gravitational value for the Laboratory is established. The effect of not doing this in the UK could be a variation in the force produced by the weight of up to approximately 0.05%, which is five times the 0.01% tolerance of the weight. Outside of the UK this variation in force could be significantly more.

It is therefore strongly recommended that you establish the local value of gravity (g) for your Laboratory and use weights that have been calibrated at that gravitational constant.

Norbar will supply weights calibrated to gravitational constants specified by the customer. However, if the customer does not specify a value for 'g', the value can be calibrated at an estimated gravitational constant for the customer's location. This will be agreed with the customer prior to calibration.

BUOYANCY EFFECTS:- _____

The Norbar system uses calibrated weights to generate a downwards force.

This means that Archimedes principle applies, i.e. air pressure under the weights causes an upwards force. This reduces the effective force generated by the weights and therefore the mass must be increased to allow for this.

Under standard conditions (i.e. Air density 1.2 kg/m^3 and 20°C and working in conventional mass terms) the increase required is by a factor of 0.015%. Weights purchased from Norbar will already have this factor taken into account.

Weights that are calibrated to standard procedures do not have this factor taken into account because the air buoyancy affects both sides of the mass balance and can be ignored. It is important that weights used for torque transducer calibration are adjusted for air buoyancy.

It should also be noted that the double ended beam design employed by Norbar means that each half of the beam is balanced with regard to buoyancy of the beam. This is a significant advantage over single-arm counterbalanced systems.

SET UP INSTRUCTIONS

The set up of this beam covers the following items:

1. Fixing Pedestal.
2. Beam & Bearing Support.
3. Levelling Gearbox.
4. Hangers.

NOTE: The set up instructions must be followed in the sequence shown.

Items required:	Spanner set. Allen key set. Spirit level (recommended accuracy +/-0.5 mm/m) 4 x Suitable fixing bolts & Drill (to suit fixing bolts).
-----------------	--

1. FIXING PEDESTAL:-

- 1.1 Ensure the floor is flat, clean and capable of supporting a weight of 480 Kg.
- 1.2 Position pedestal to allow access around the calibration beam when assembled.

NOTE: Fixing bolts NOT included.

Customer must supply 4 off M10 Fixing bolts to suit their concrete floor.

Pull out force on fixing bolts must exceed 2.5 kN.

Ensure the concrete floor is capable of taking 30 N/mm².

Tighten fixing bolts to achieve a minimum of 6 kN tension in the bolts.

- 1.3 Drill concrete floor to accept the fixing bolts.
Fit fixing bolts to hold pedestal to floor, do not fully tighten yet.
- 1.4 Locate jacking plates (supplied) under jacking screws, as shown in figure 2.

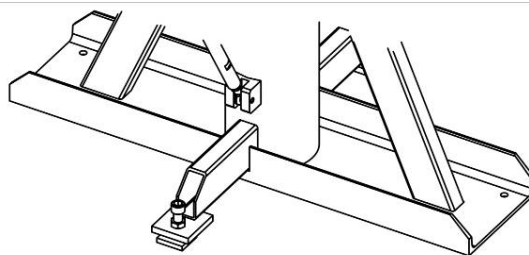

Figure 2. Pedestal base with fixing holes & jacking screws.

- 1.5 Place a spirit level on the machined surface of the pedestal bed and adjust jacking screws to ensure pedestal is level. For correct calibration it is essential the pedestal is level in all directions.
- 1.6 Fully tighten the raw bolts to the required torque.
- 1.7 Check pedestal bed is level.

2. BEAM & BEARING SUPPORT



**WARNING: THE BEAM & BEARING SUPPORT IS HEAVY.
THIS TASK REQUIRES MORE THAN 1 PERSON.**

- 2.1 Line up the bearing support with holes in the middle of the bed.

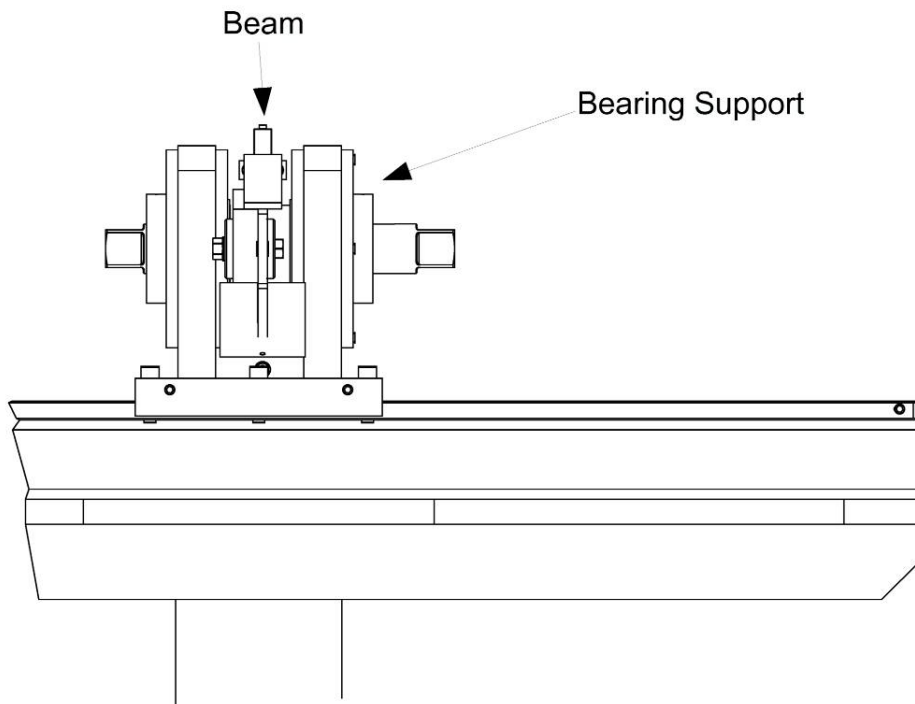

Figure 3. Location of beam & bearing support.

- 2.2 Position of beam is established by fitting bearing support with 2 off M8 shoulder bolts supplied. Tighten to 10 N·m.
- 2.3 Fix using 6 off M12 bolts supplied. Tighten to 80 N·m.
- 2.4 Fit 2 off guide plates to bed. Tighten 4 off M8 bolts to 10 N·m.

3. LEVELLING GEARBOX

- 3.1 Remove M6 end stop screw from pedestal bed.
- 3.2 Line up the levelling gearbox with the slots in the pedestal bed then slide on. Ensure drive square input is facing beam as shown in figure 4.

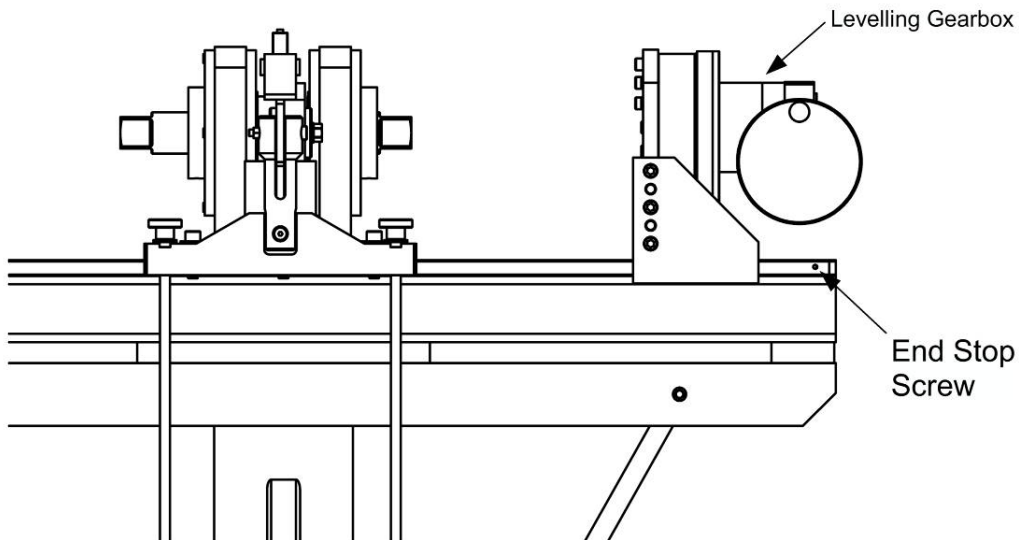

Figure 4. Location of levelling gearbox.

- 3.3 Fit M6 end stop screw to pedestal bed.

4. HANGERS

TIP. The hangers are supplied ready to attach to the beam. Ensure the correct hanger is fixed to the correct end of the beam. If the hanger assembly is taken apart, DO NOT mix parts with the other hanger assembly.

- 4.1 Bolt hanger marked "XX" to beam end marked "XX". Bolt hanger marked "YY" to beam end marked "YY". Choose a location (A, B, C, D, E, F, G or H) for each beam, the required location is set in the Operating Instructions.
- 4.2 Place weight platform under hanger to be loaded, as shown in figure 5.

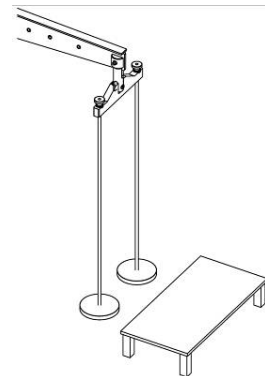

Figure 5. Hanger weight platform.

OPERATING INSTRUCTIONS



WARNING: KEEP HANDS CLEAR OF MOVING PARTS DURING USE.

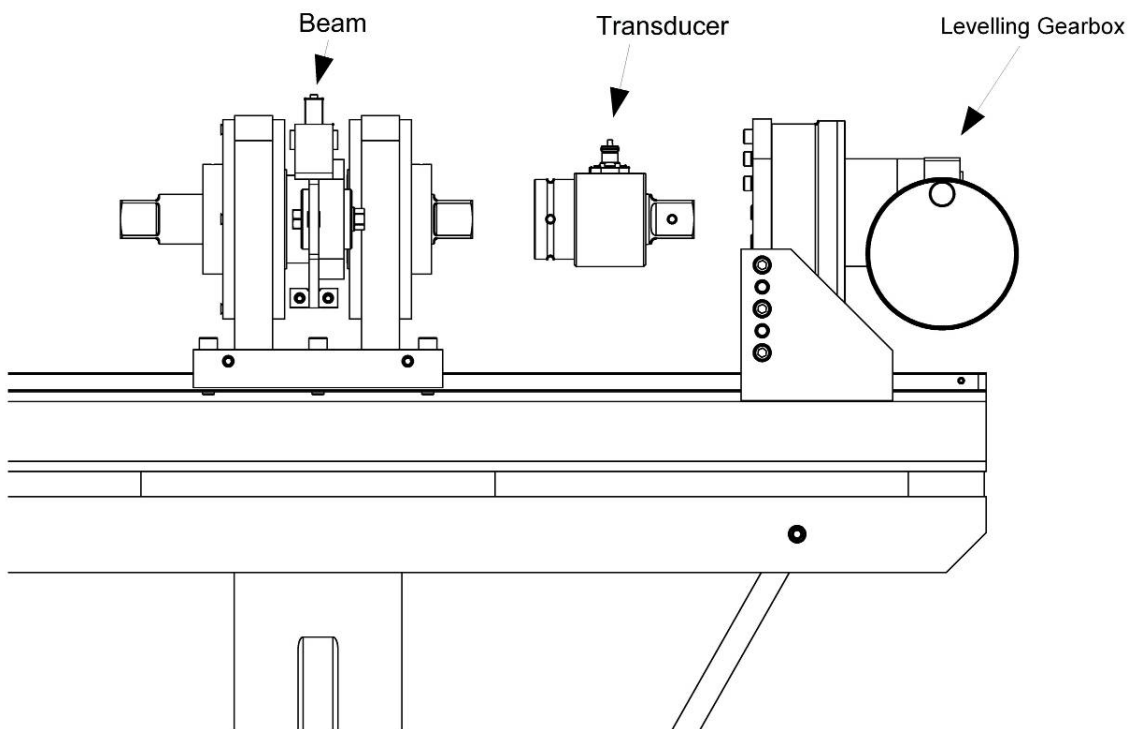
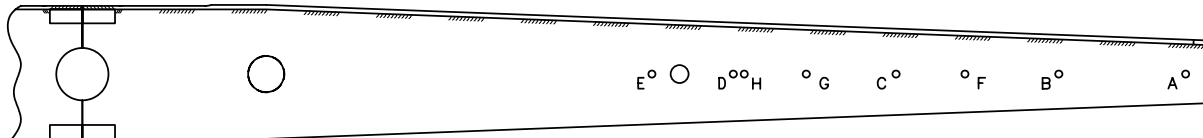

Figure 6. Location of transducer.

TIP. This is a general procedure to use the calibration beam.
Use this procedure along with any specific standard being followed.

1. LOCATING TRANSDUCER _____

- 1.1 Connect transducer to display unit required. Zero reading on display.
- 1.2 Mount the transducer between beam & levelling gearbox using appropriate adaptors, see figure 6. Slide the levelling gearbox so the transducer drive squares are fully engaged.
- 1.3 Allow the required warm up time for transducer & display; a minimum twenty (20) minutes is recommended.

2. LOCATING HANGERS**Figure 7. Beam location holes.**

- 2.1 The beam has many location holes for the hangers, see figure 7. The required location depends on the torque required & the weights used. Use the following table to determine the hanger location.

Location	Distance		Force		TORQUE (Force x Distance)	Absolute maximum torque for overload test
	m	ft	N	lbf		
A	1.52400	5	4,448.22	1000	5000 lbf-ft	110%
B	1.34885	-	4,448.22	1000	6000 N-m	110%
C	1.12404	-	4,448.22	1000	5000 N-m	110%
D	0.899236	-	4,448.22	1000	4000 N-m	110%
E	0.786832	-	4,448.22	1000	3500 N-m	110%
F	1.21920	4	4,448.22	1000	4000 lbf-ft	110%
G	1.00000	-	*	*	*	110%
H	0.91440	3	4,448.22	1000	3000 lbf-ft	110%

* = For use with metric weights.

- 2.2 Bolt the hangers to the required location.
Ensure that the correct hanger is located at each end of the beam.
- 2.3 Place weight platform, figure 5, under hanger to be loaded.

NOTE: The hangers must be loaded equally, so weights are added in pairs.

3. EXERCISING

- 3.1 It is recommended to exercise the transducer before calibration; this can be done by loading to full scale then removing the weights three (3) times.
The display output should be watched during this process to avoid overloading.

The exercising procedure is:

- A. Apply torque by adding the required weights to the hangers, then winding the handle on the levelling gearbox until full scale torque is displayed.
- B. Decrease torque by un-winding the handle on the levelling gearbox until the display reads the minimum value and weights are firmly seated on weight platform.
- C. Repeat steps A & B two more times.
- D. Remove all weights.
- E. Ensure transducer display is set to zero before calibration.
The levelling gearbox may need to be removed from the transducer to get a true zero.

4. CALIBRATION

- 4.1 The transducer is loaded in the required increments.
Gentle application of the weights is advised to maintain a steady reading.

At each torque increment the procedure is:

- A. Place weights onto hangers, loading the twin hangers equally.
- B. Wind the handle on the levelling gearbox to lift the weights clear of the weight platform.

- C. Level beam using the levelling gearbox.
Ensure the beam spirit level reads correctly, see figure 8.

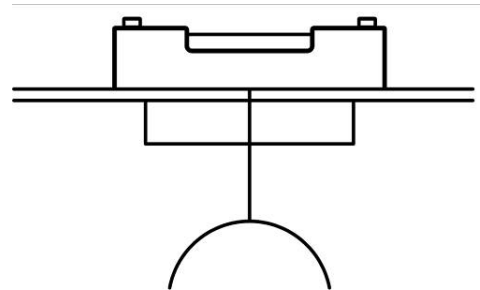

Figure 8. Beam spirit level.

- D. Waiting for the reading to stabilise.
- E. Take torque reading from display.
- F. The next torque increment can be taken.
- G. After the last increment remove all weights.
Remove levelling gearbox from transducer.
A final zero result can be measured.

NOTE: If the transducer needs adjusting refer to appropriate operator's handbook or service manual.

NOTE: For reverse calibration the weights are applied to the opposite hangers. The transducer will need to be exercised in the reverse direction before calibration.

MAINTENANCE

BEAM REPAIR & RECALIBRATION

Norbar Supported Calibration Beams are designed for transducer calibration at low levels of uncertainty. They are robust for normal handling by technicians, but if dropped or otherwise damaged, may lose their calibration integrity. It is therefore essential that the beam is recalibrated after any such incident.

Recalibration involves establishing the beam length from the centre of the driving square to a locus of points on the beam end. (See original calibration certificate for further details). This is difficult to achieve with conventional length standards, although use of a Co-ordinate Measuring Machine may give satisfactory results. Planned calibration intervals will depend of usage, and should be decided by the laboratory.

Norbar offers a full repair and recalibration service, with traceable certification of status before and after repair. Due to the complex nature of the beams, please contact Norbar in the event of any damage requiring repair.

WEIGHT RECALIBRATION

It should be possible to obtain local recalibration of weight sets. Please contact Norbar if further assistance is required.

SPECIFICATIONS

Absolute maximum torque:	110% (for each beam location).
Recommended temperature:	20°C +/- 2°C.
Humidity:	30% to 70%.
Location hole accuracy:	+/- 0.01% of nominal.

TROUBLE SHOOTING

Problem	Solution
Can not achieve zero torque.	Levelling gearbox causing small load, remove levelling gearbox.

GLOSSARY OF TERMS

Term	Meaning
Bearing Support	Centre of beam rotation.
Class M1	Weight classification.
Hanger	Device to hold weights.
Pedestal	Main support for calibration beam.
Weight Platform	Device to rest weights on between tests.
Levelling Gearbox	Device to ensure beam is level.