



PNEUTORQUE[®] 500/1000/1500 SERIES

REMOTE AIR MOTOR OPTION

OPERATORS HANDBOOK (PART NO. 34067)

NOISE

These power tools are tested in accordance with BS ISO 3744: 1994 Acoustics – Determination of sound power levels of noise sources using sound pressure – Engineering method in an essentially free field over a reflecting plane.

Test conducted in free running condition with a supply pressure of 80psi.

Equivalent continuous A weighted sound pressure level – 85 dBA – measured at 1m.

For more in-depth noise test results contact your local distributor or Norbar's Engineering Department.

Method of Sound Level Measurement: CEN/TC 255 N 184

Pneutorque Wrenches supplied with remote control air motors are intended for use either as part of a purpose built tightening fixture where the controls are required to be sited apart from the tool, or for multi-spindle applications.

IMPORTANT: DO NOT OPERATE THE TOOL BEFORE READING THESE INSTRUCTIONS.

These wrenches are reversible, non-impacting, torque controlled bolt tightening tools and must always be operated with the following:-

- Clean dry air supply with a minimum flow of 11 litres/sec (23 CFM).
- Air Control System.
- Impact or Machine Quality Sockets.
- Tool mounting fixture.

Where the intended usage is not with threaded fasteners, the safety of operation must be evaluated and appropriate precautions taken. Your distributor will be pleased to advise you.

These tools contain grease, which may cause an explosion hazard in the presence of pure oxygen. These tools contain aluminium alloy components which may cause a hazard in certain explosive environments. Please contact your distributor for details of solutions to these hazards.

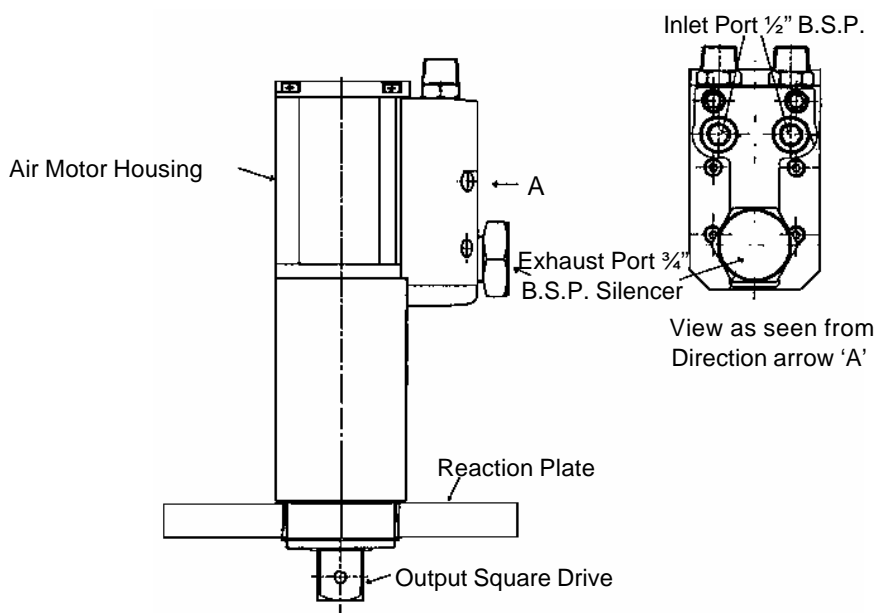

FIG 1

TORQUE REACTION

When Pneutorque Wrenches are supplied individually with remote control air motors, a blank double-sided reaction plate is fitted as standard (see Figure 2).

The wrench must be mounted using this reaction plate, and in such a way as to withstand the torque reaction force, which is equal and opposite to the output of torque.

The tool can be re-positioned relative to the reaction plate by removing the circlip at the base of the tool, removing the plate and refitting in the correct position. Ensure that the circlip is re-fitted correctly.

Alternative reaction plates, and technical assistance are available through your local distributor.

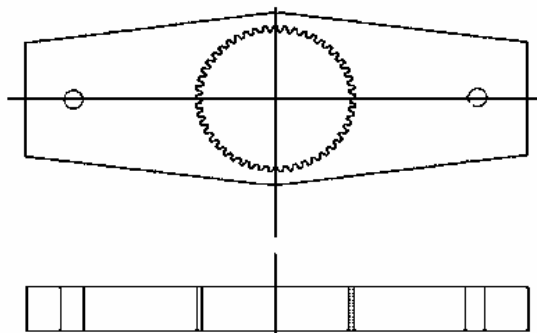

FIG 2

TOOL CONTROL SYSTEMS

The remote control air motor requires a separate air valving system (not supplied) for on/off and forward/reverse control.

The direction of rotation of the motor is determined by pressurising either the forward or reverse air inlet ports. The exhaust port is common to both inlet ports and requires an external silencing device. (see Figure 2). The hose size used for the exhaust air must not be reduced from 3/4" (19mm) or the wrench performance will be impaired.

All air supply hoses and control valves must be 1/2" bore (12mm) and the hose from the supply to the control system must not be longer than 5 metres or the wrench performance will be impaired. If the supply hose must be longer than 5 metres then 3/4" bore must be used.

Examples of air control circuits are shown in Figure 3 and Figure 4.

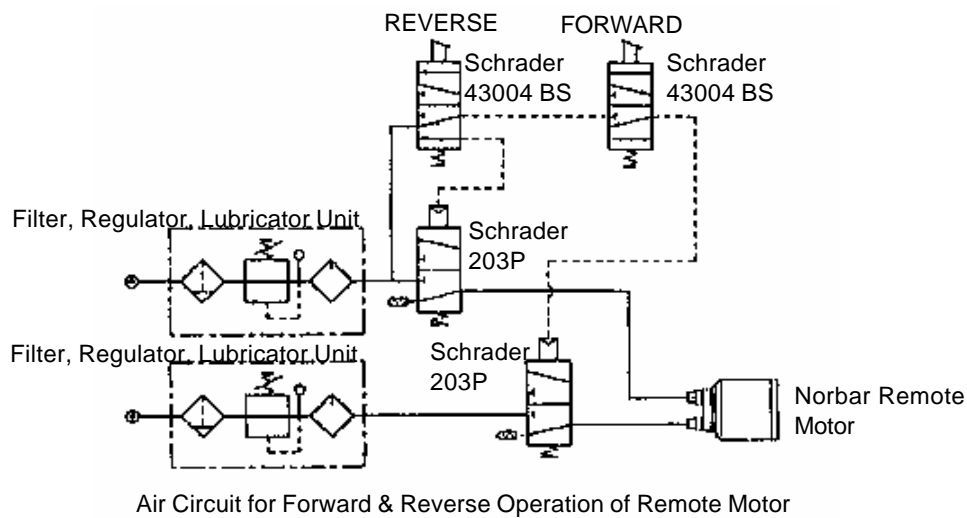
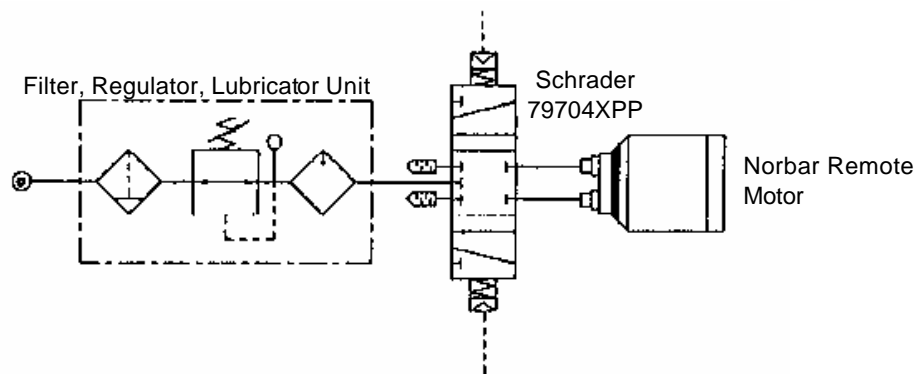

FIG 3



Control Circuit for Operating Air Motor by Remote Electrical Signal

FIG 4

SETTING TORQUE FOR BOLT TIGHTENING

Every Pneutorque Wrench is supplied with an Air Pressure Graph which relates torque output to air pressure. Set the torque output as follows:-

1. Ensure the control system is set for forward rotation.
2. Establish the air pressure required using the Air Pressure Graph.
3. Adjust the 'forward' pressure regulator until the correct pressure is achieved.

IMPORTANT: THE WRENCH MUST BE FREE RUNNING WHILE ADJUSTING THE AIR PRESSURE TO GIVE THE CORRECT SETTING.

WHILE THE WRENCH IS FREE RUNNING CHECK THAT LUBRO CONTROL UNIT IS SUPPLYING APPROXIMATELY SIX DROPS OF OIL PER MINUTE.

SETTING TORQUE FOR BOLT LOOSENING

1. Ensure that the control system is set for reverse rotation.
2. Establish maximum air pressure from Air Pressure Graph or tool label and set air pressure as for bolt tightening.
3. Adjust the 'reverse' pressure regulator until the correct pressure is achieved.

WARNING: EXCEEDING THE MAXIMUM AIR PRESSURE WILL OVER LOAD THE WRENCH AND MAY CAUSE SERIOUS DAMAGE.

OPERATING THE WRENCH

WARNING: ALWAYS KEEP HANDS CLEAR OF REACTION PLATE AND DRIVE SOCKET WHEN TOOL IS IN OPERATION OR SERIOUS INJURY MAY RESULT.

1. Fit the wrench with the correct size impact or machine quality socket to suit the bolt to be tightened.
2. Check control system is set for correct direction of rotation.
3. Fit the tool onto the bolt to be tightened.

WARNING: IN USE, THIS TOOL MUST BE SUPPORTED AT ALL TIMES IN ORDER TO PREVENT UNEXPECTED RELEASE IN THE EVENT OF FASTENER OR COMPONENT FAILURE.

4. Start the tool and allow it to continuously tighten the bolt, full torque will not be applied until the motor stalls.
5. Stop the tool and remove from bolt.

MAINTENANCE

To maintain optimum performance and safety unscrew the silencer and wash it in a solvent every six months.

LUBRICATION

Air Lubricator and Air Motor:-

Shell Tellus 15 or equivalent good quality hydraulic oil.

Gearbox:-

BP Energrease LS-EP1 or equivalent good quality grease. Under normal operating conditions it is not necessary to re-grease the gearbox.

Manufacturer's Name and Address:

| |
|--|
| Norbar Torque Tools Ltd Beaumont Road Banbury Oxfordshire OX16 1XJ United Kingdom Tel: + 44 (0) 1295 270333 Fax: + 44 (0) 1295 753643 www.norbar.com |
|--|

For Service Contact:

| |
|--|
| |
|--|